



Free 5'x6' Chicken Coop Plan

Free vs. Premium Plan: What's the Difference?

We offer both free and premium versions of our detailed shed plans, designed to fit your needs and budget. Check out the table below to see the key differences and choose the plan that's right for you:

Features	Free Plan	Premium Plan
Steps Count	13	38
Illustrations per Step	Limited	Every Step
Print Ready Format	X	✓
Step-by-Step Instructions	Basic	Comprehensive
Full Materials & Cutting List	X	✓
Additional Illustrations	X	✓
Additional Blueprints	X	✓
Tools List	X	✓
Fastening Elements List	X	✓
Technical Support	X	✓

[Try Premium Risk-Free](#)

60-day refund policy with no questions asked.

5' x 6' chicken coop shopping list

Material	Unit	Qty	Size
Pressure-Treated Lumber (1/4" x 1")	pcs	5	6'
Pressure-Treated Lumber (1" x 2")	pcs	2	6'
Pressure-Treated Lumber (1" x 3")	pcs	25	6'
Pressure-Treated Lumber (1" x 4")	pcs	4	6'
Pressure-Treated Lumber (1" x 4")	pcs	2	8'
Pressure-Treated Lumber (1" x 6")	pcs	3	8'
Pressure-Treated Lumber (2" x 2")	pcs	5	6'
Pressure-Treated Lumber (2" x 3")	pcs	2	8'
Pressure-Treated Lumber (2" x 4")	pcs	24	6'
Pressure-Treated Lumber (4" x 4")	pcs	10	6'
Pressure-Treated Lumber (4" x 4")	pcs	6	8'
Plywood (5/8")	pcs	13	4' x 8'

Size & Dimensions

front

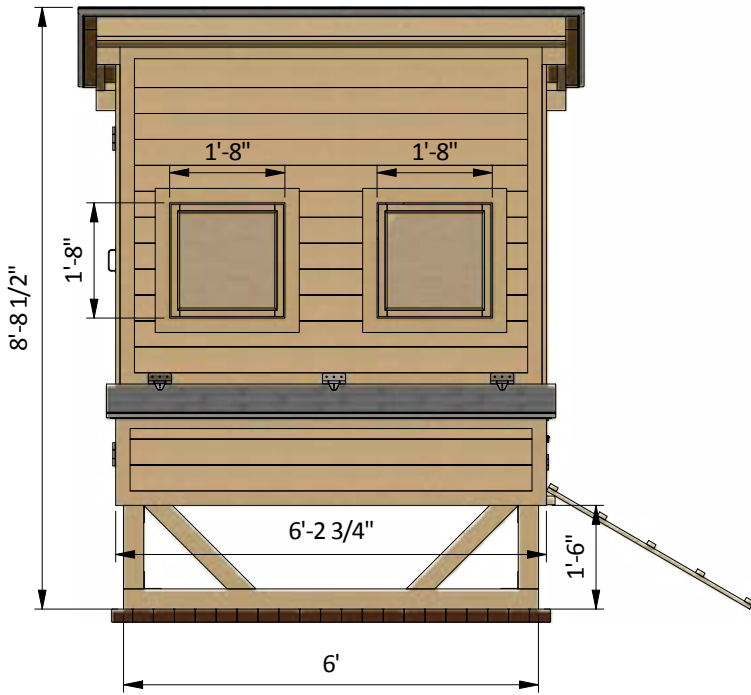

left

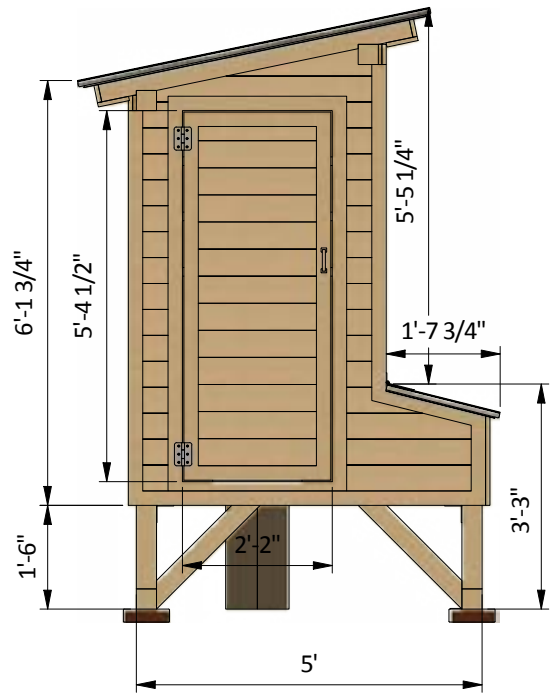

back

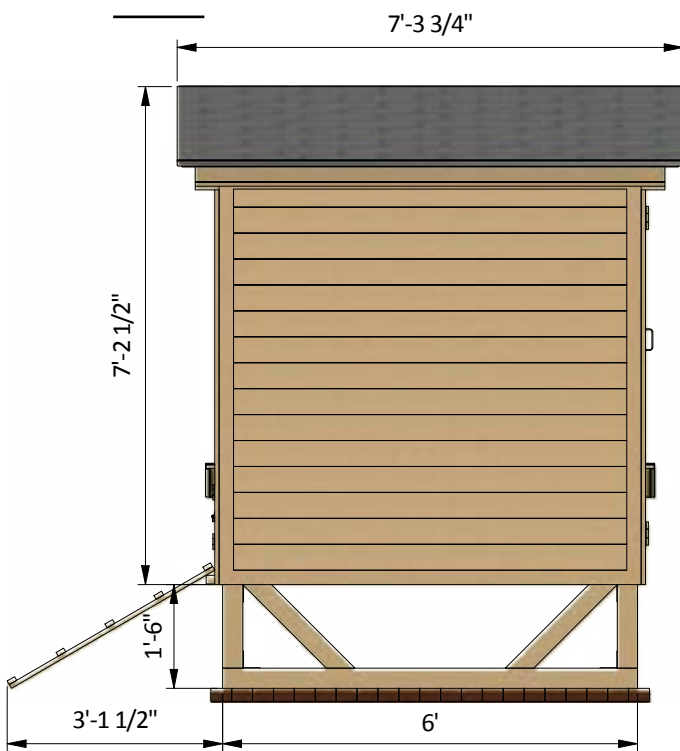

right

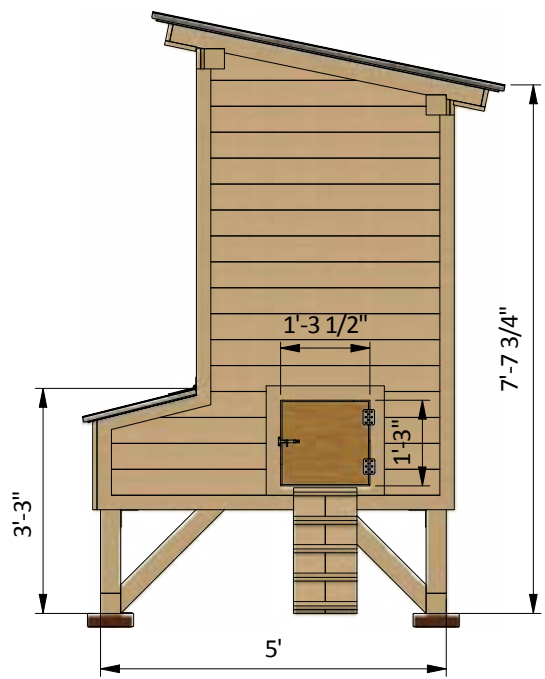

STEP 1

Ground Works

1.1 Clear the area where you want to build the shed and layout for the foundation. Use the below illustration as a guide.

1.2 For the foundation, dig the trenches at least 1' wide and 1' deep.

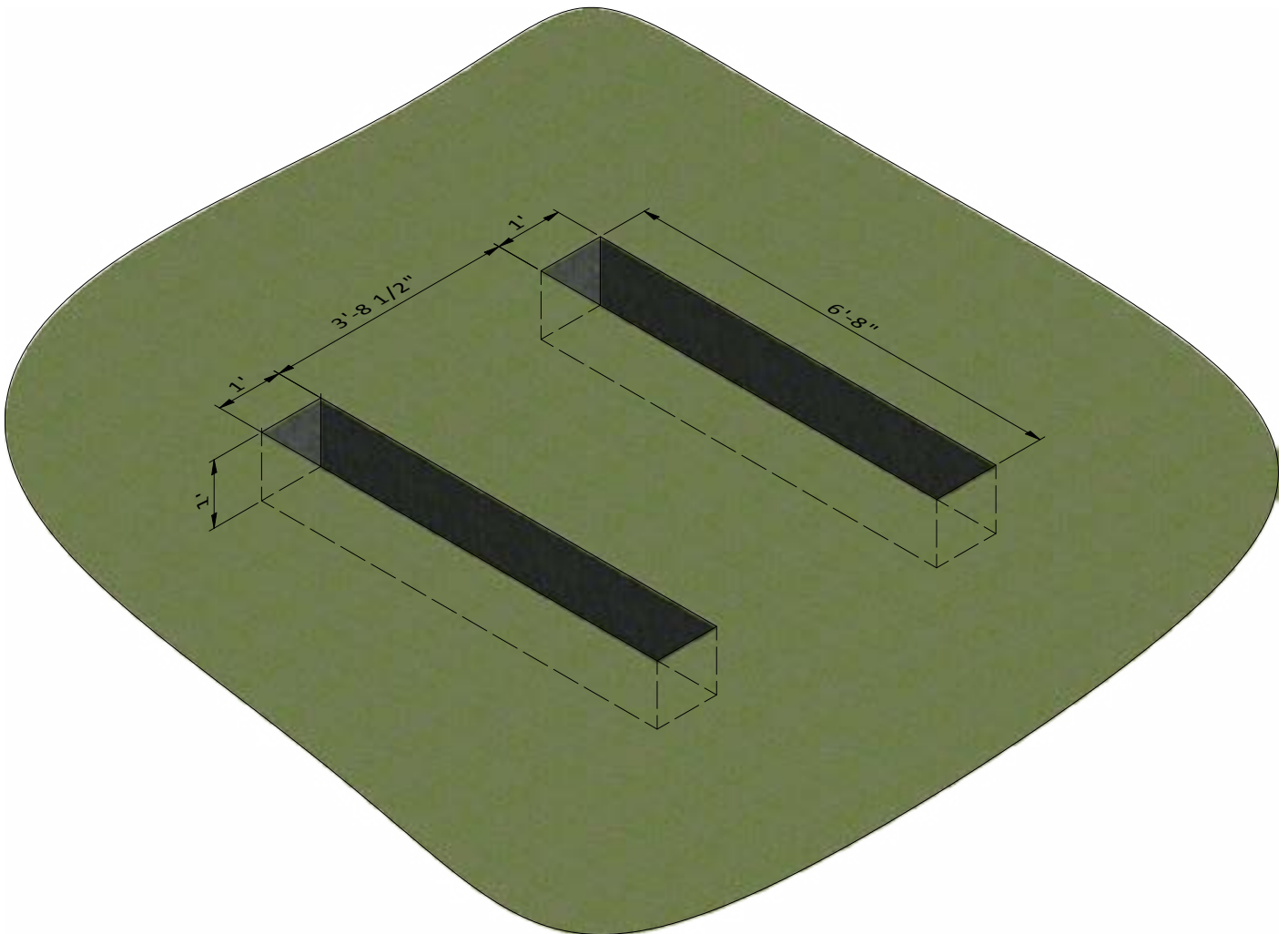

STEP 2

Assemble the Main Frame

2.1 Using 3 1/2" x 3 1/2" pressure-treated lumber, install the beams using the drawing below as a reference. You will need two boards cut to 6'-11" and two boards cut to 1'-2 1/2" that will be studs, two boards cut to 5'-5" and two boards cut 4'-8 1/2" that will be horizontal girts, two boards cut to 6' that will be bottom plates.

2.2 Secure the beams to the bottom rails with 5", 2" wood screws and 3" x 3" corner brackets.

2.3 Using a speed square or carpenter's square, check the corners to make sure they are 90°.

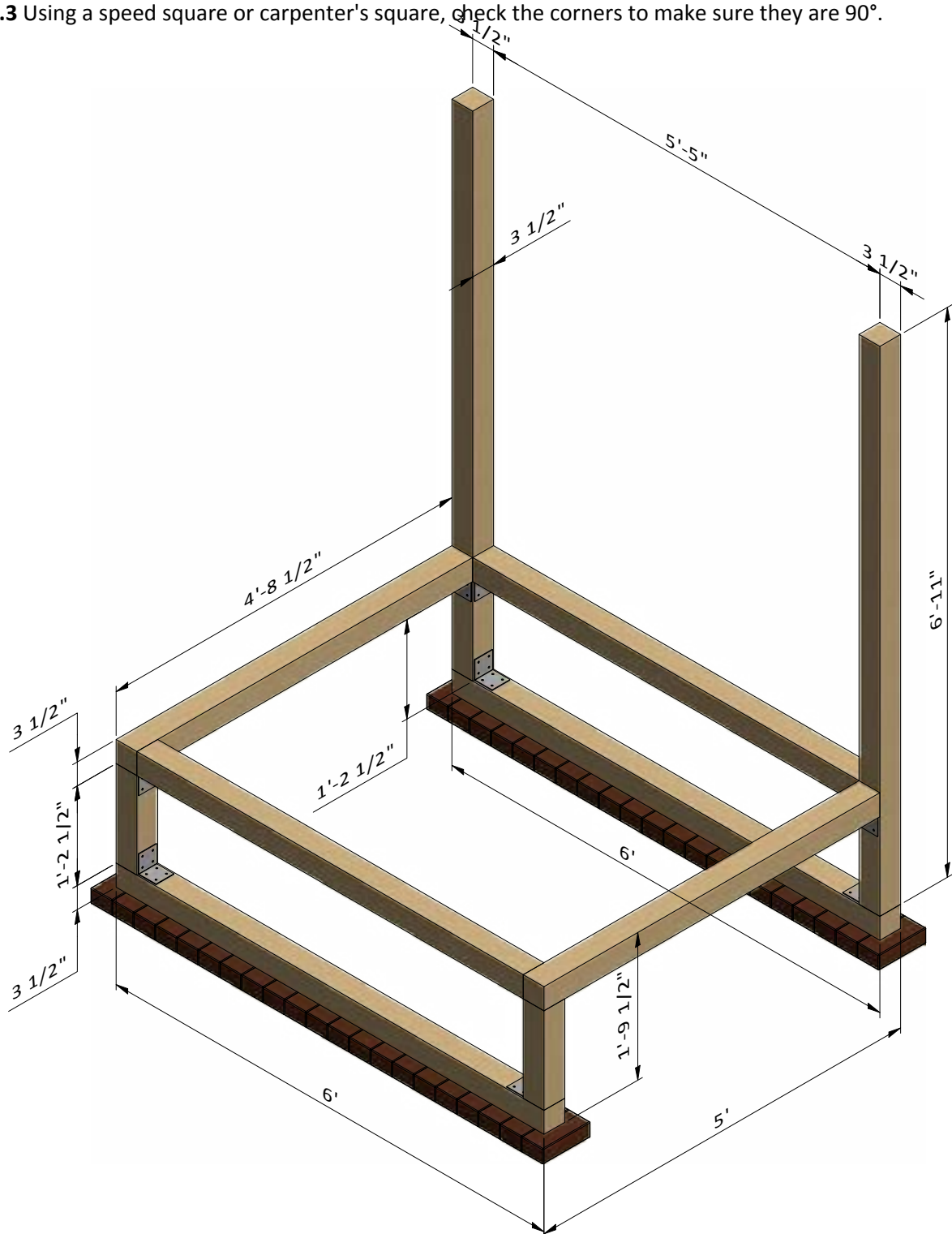

STEP 3

Assemble the Main Frame

3.1 Using 3 1/2" x 3 1/2" pressure-treated lumber, install the beams using the drawing below as a reference. You will need two boards cut to 6'-1" that will be studs and two boards cut to 5'-5" that will be horizontal girts.

3.2 Secure the beams to the bottom rails with 5", 2" wood screws and 3" x 3" corner brackets.

3.3 Using a speed square or carpenter's square, check the corners to make sure they are 90°.

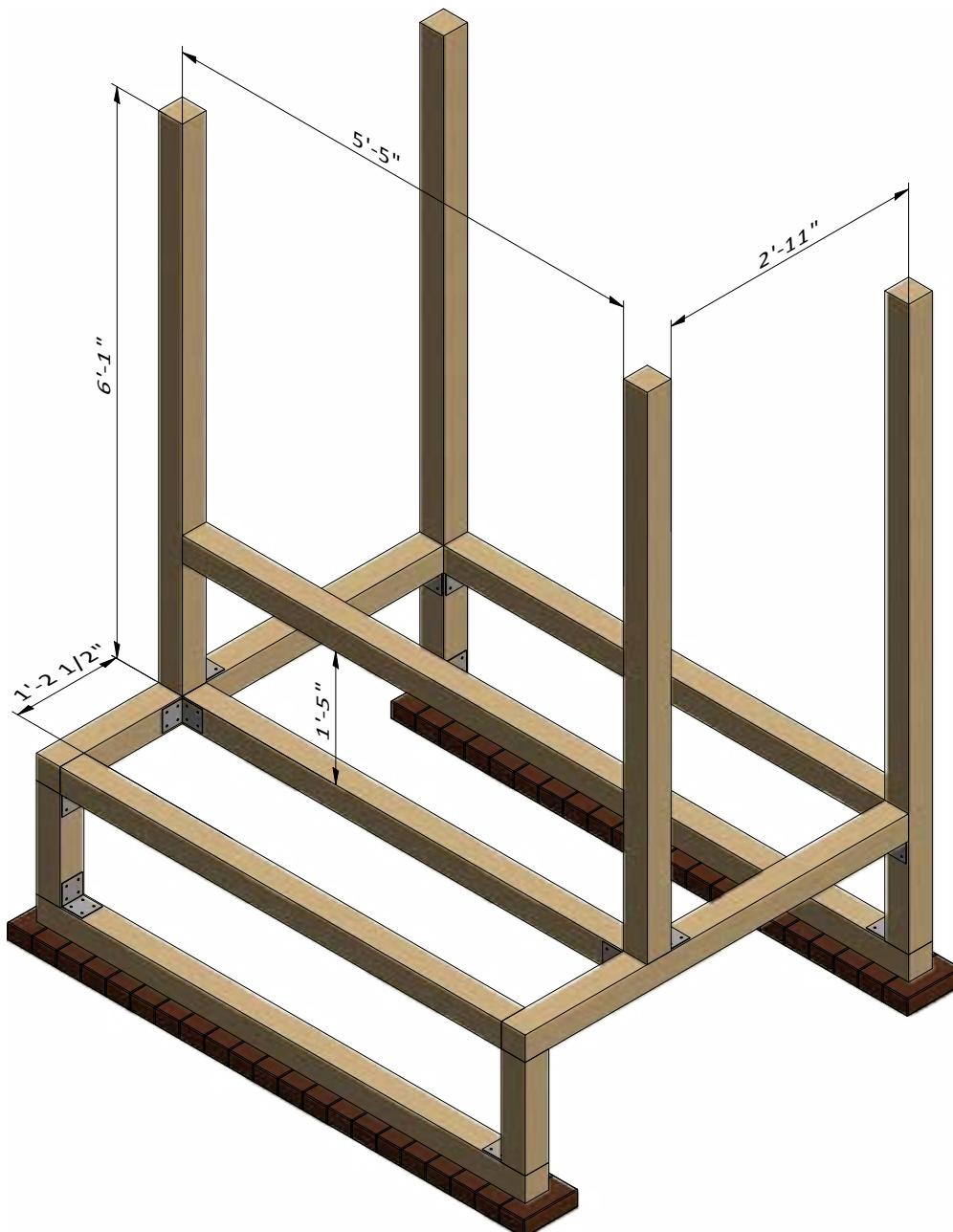

STEP 4

Assemble Front Wall Frame

4.1 Using 1 1/2" x 3 1/2" pressure-treated lumber, construct front wall frame using the drawing below as a reference. You will need four boards cut to 4'-4 1/2" that will be studs and four boards cut to 1'-8" that will be the window headers and rough sills.

4.2 Connect the beams with 3" and 5" wood screws.

4.3 Using a speed square or carpenter's square, check the corners to make sure they are 90°.

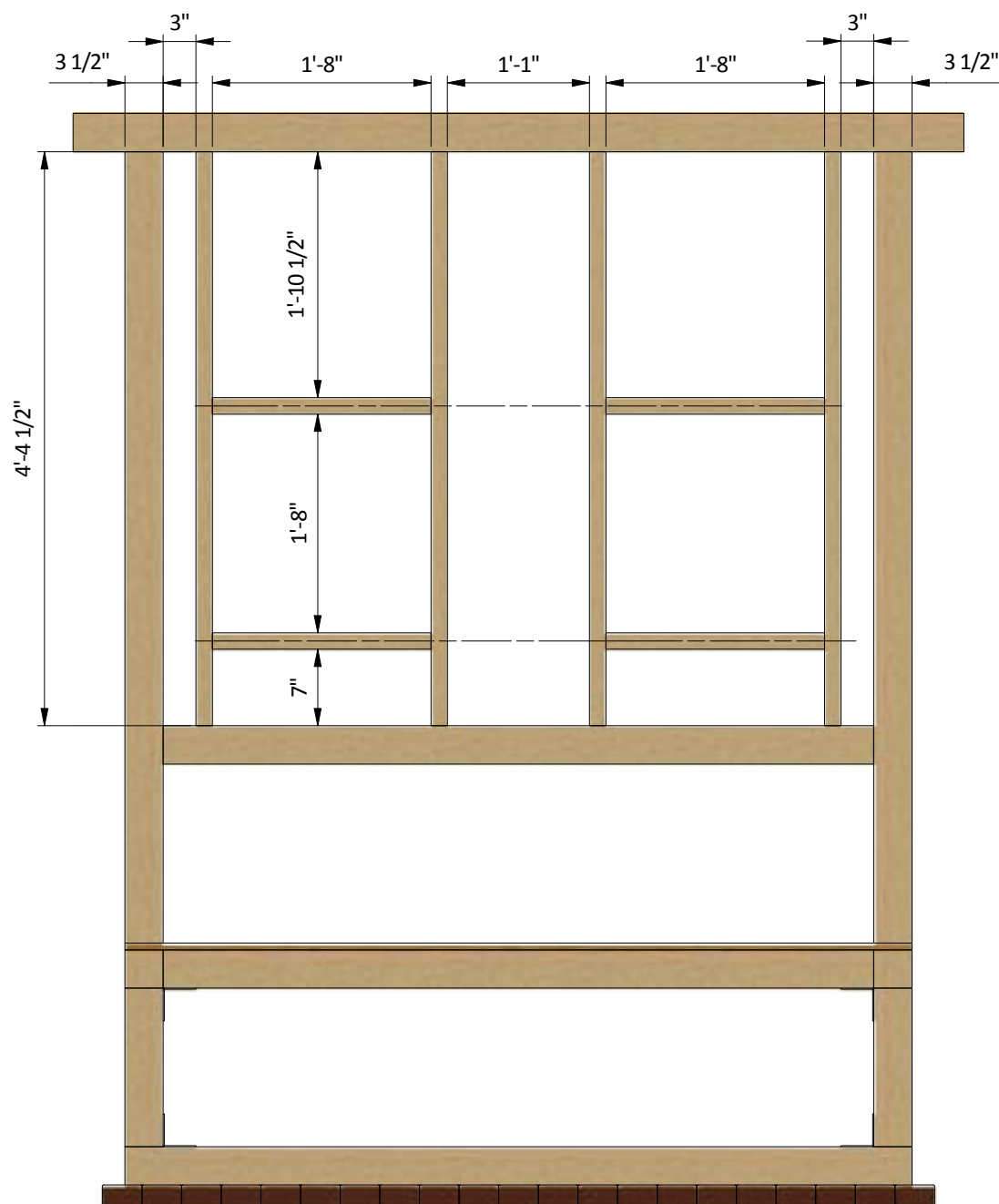

STEP 5

Assemble Back Side Wall Frame

5.1 Using 1 1/2" x 3 1/2" pressure-treated lumber, construct back side wall frame using the drawing below as a reference. You will need four boards cut to 5'-4 1/2" that will be studs.

5.2 Connect the beams with 3" wood screws.

5.3 Using a speed square or carpenter's square, check the corners to make sure they are 90°.

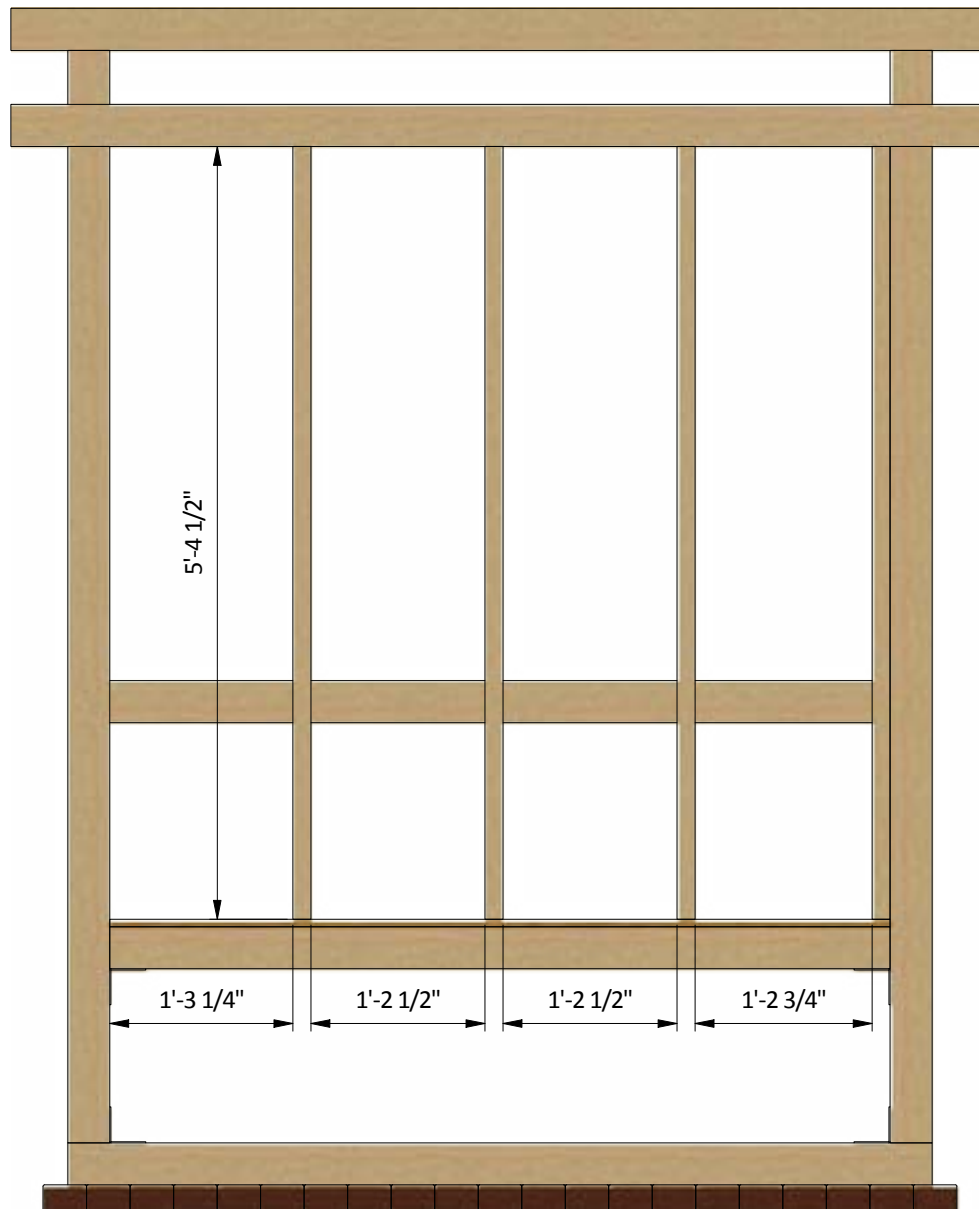

STEP 6

Assemble Left Side Wall Frame

6.1 Using 1 1/2" x 3 1/2" pressure-treated lumber, construct left side wall frame using the drawing below as a reference. You will need two boards cut to 5'-4 1/2" that will be studs.

6.2 Connect the beams with 3" wood screws.

6.3 Using a speed square or carpenter's square, check the corners to make sure they are 90°.

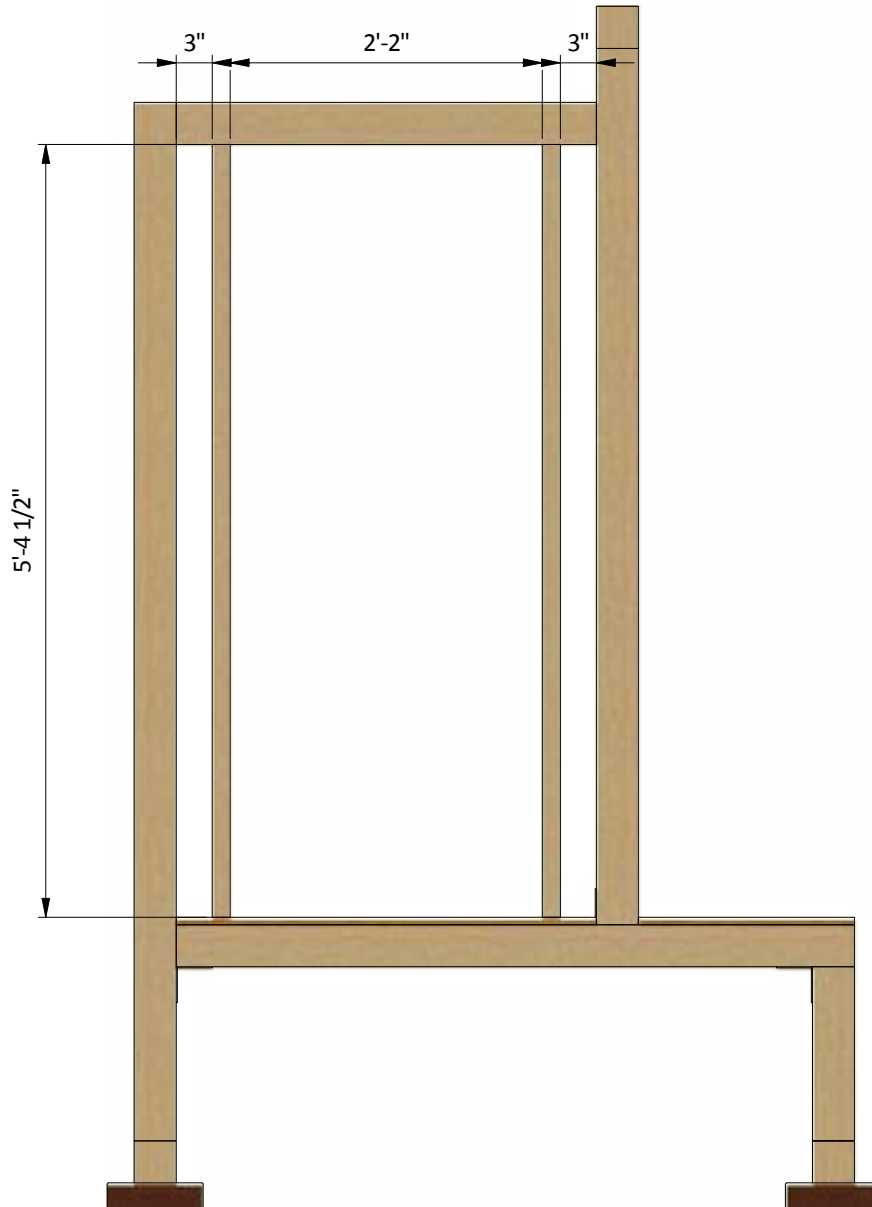

STEP 7

Assemble Right Side Wall Frame

7.1 Using 1 1/2" x 3 1/2" pressure-treated lumber, construct right side wall frame using the drawing below as a reference. You will need two boards cut to 5'-4 1/2" that will be studs and one board cut to 1'-3 1/2" that will be the door header.

7.2 Connect the beams with 3" wood screws.

7.3 Using a speed square or carpenter's square, check the corners to make sure they are 90°.

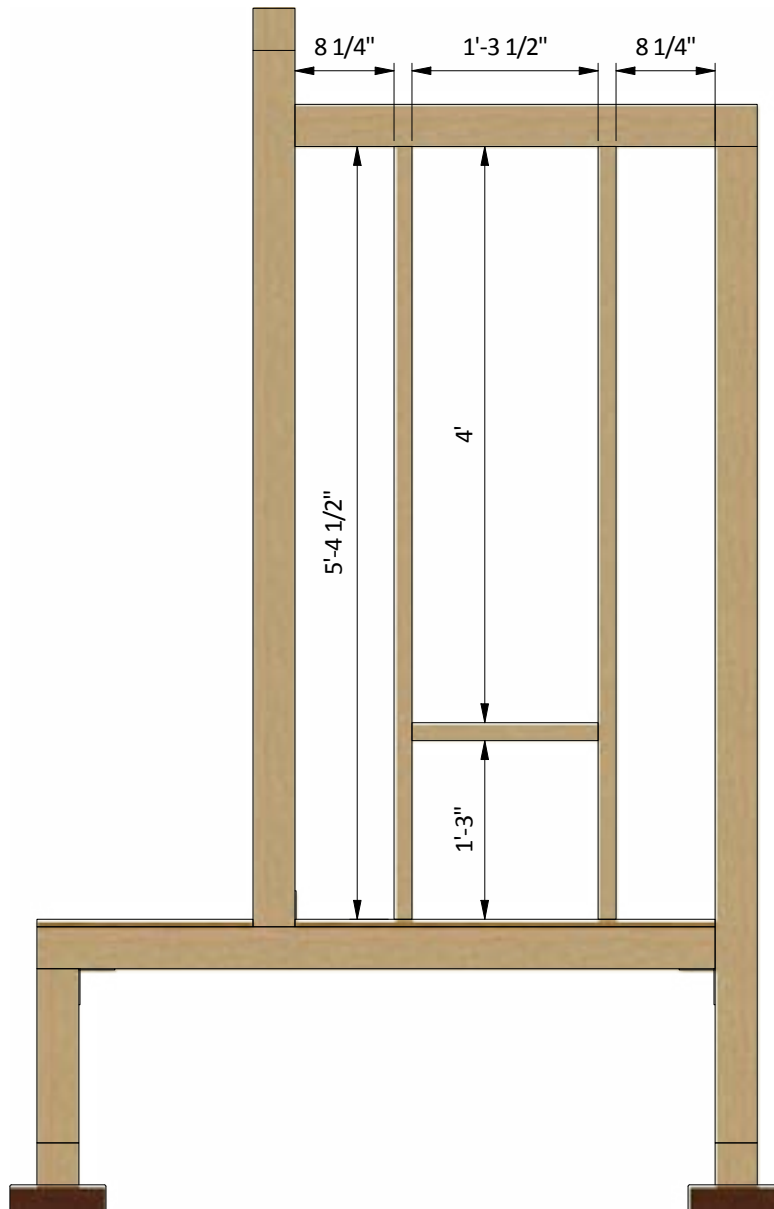

STEP 8

Assemble the Roof Frame

8.1 Using 1 1/2" x 3 1/2" pressure-treated lumber, cut eight rafters 4'-7 1/4" long according to the dimensions in drawings below. Cut the recesses for connection with top plates.

8.2 Connect the beams with 5" wood screws.

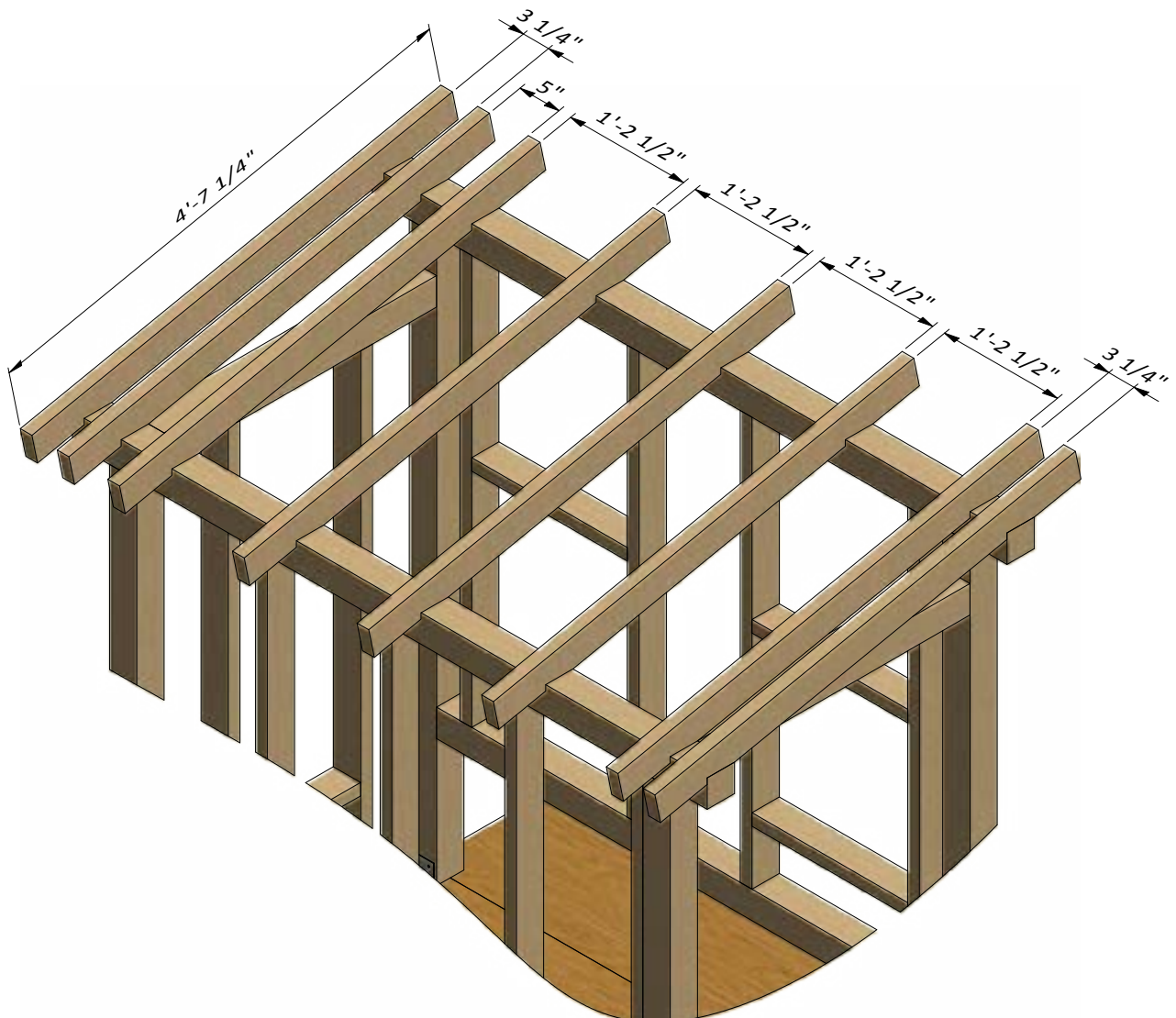
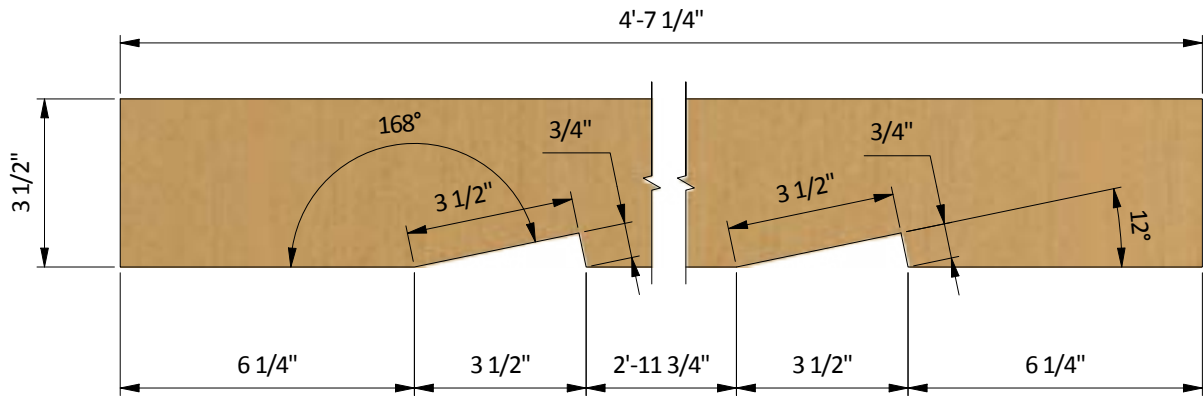

STEP 9

Assemble and Install Left Wall Door

9.1 Build the door frame using $3/4"$ x $3\ 1/2"$ pressure-treated lumber and secure with 5" wood screws. You will need two boards cut to 4'-9" that will be the vertical girts, two boards cut to 2'-1 $1/2"$ that will be the horizontal girts, and one board cut to 4'-11 $3/4"$ that will be cross brace.

9.2 Prepare the $5/8"$ plywood sheet with dimensions 2'-1 $1/2"$ x 5'-4" for the door according to the drawing.

9.3 Use $3/4"$ x 2 $1/2"$ pressure-treated lumber for the door trim and fasten with 2" wood screws. You will need two boards cut to 2'-1 $1/2"$ and two boards cut to 4'-11".

9.4 Using $1/4"$ x $3/4"$ pressure-treated lumber, cut and install a starter course 1'-8 $1/2"$ long using node E on page 33 as a reference.

9.5 For the exterior siding on the door, use $1/2"$ x 6" wood siding boards and the illustration below as a reference.

9.6 Assemble siding shields with 2" galvanized nails.

9.7 Install two 3" door hinges using 6x1" wood screws. Finish the doors installation by attaching 6" door pull (see nodes **F**, **G**).

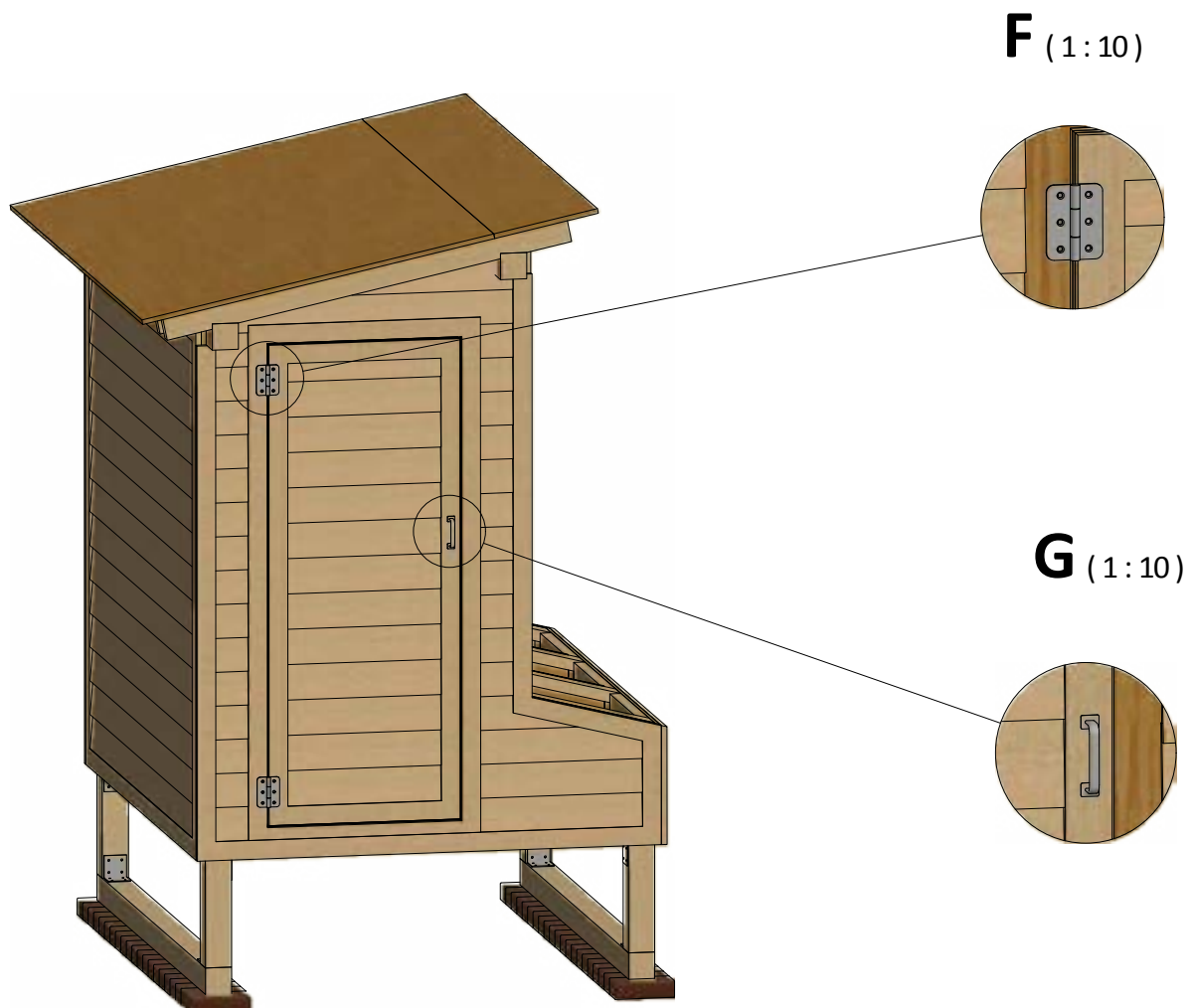

STEP 10

Assemble and Install Windows

You will need to prepare two windows.

10.1 Using 1 1/2" x 1 1/2" pressure-treated lumber, assemble the outer frame for the window as shown in the drawing below. You will need four boards cut to 1'-7 1/2" that will be the vertical and horizontal girts. Cut the recesses in each beam for splicing connection and mill a recess for the glass.

10.2 Prepare and install 1'-5 1/4" x 1'-5 1/4" glass into inner frame groove and fasten it by window beading from four sides. Use 1/2" galvanized nails.

10.3 Insert window into wall openings and connect them with 3" wood screws to the wall beams.



STEP 11

Coop's Roof Sheathing Installation

11.1 Prepare metal drip edge with 6" width. You will need 25' to cover all the perimeter.

11.2 Place the drip edge down, aligning it to the plywood edge. Use 2" nails to secure the first drip edge. When you place the next drip edge piece, it should overlap the first by an inch.

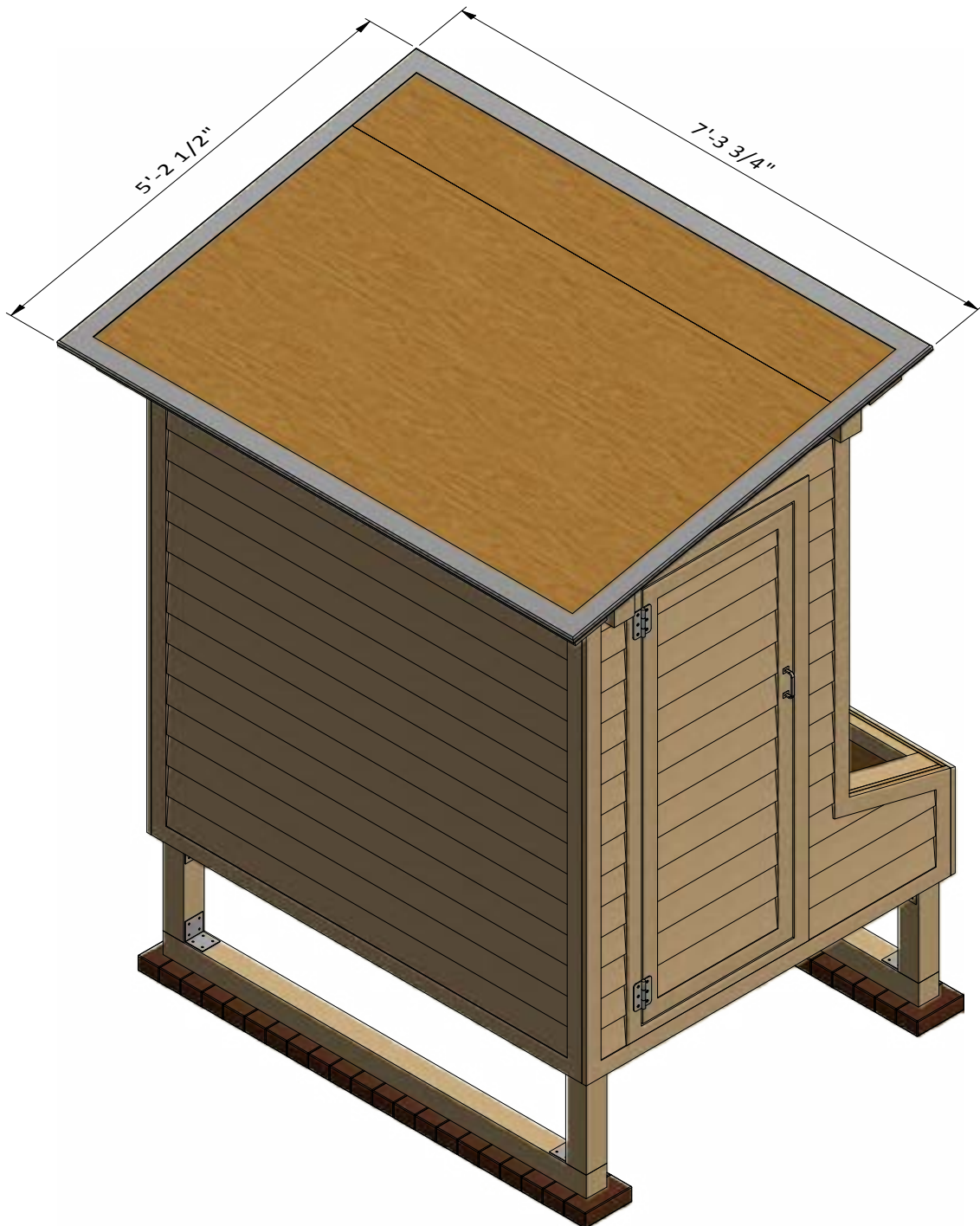

STEP 13

Thank You

Now that your chicken run is all done, you can decorate it using your favorite paint, stain, or preservative and prepare for petting chickens.



Free vs. Premium Plan: What's the Difference?

We offer both free and premium versions of our detailed shed plans, designed to fit your needs and budget. Check out the table below to see the key differences and choose the plan that's right for you:

Features	Free Plan	Premium Plan
Steps Count	13	38
Illustrations per Step	Limited	Every Step
Print Ready Format	X	✓
Step-by-Step Instructions	Basic	Comprehensive
Full Materials & Cutting List	X	✓
Additional Illustrations	X	✓
Additional Blueprints	X	✓
Tools List	X	✓
Fastening Elements List	X	✓
Technical Support	X	✓

[Try Premium Risk-Free](#)

60-day refund policy with no questions asked.



For more great **HOW-TO** plans please visit: <https://craft.camp>

Copyright

The text and illustrations that appear here are the exclusive property of craft.camp and are protected by federal copyright laws. The duplication, sale or distribution of any portion of these plans without prior written consent from the original designer will be subject to the appropriate penalties for copyright infringement. Sharing this plan on the web is only permitted with an indicated original source: <https://craft.camp>